

Pulse Tube Cryocooler for Rapid Cooldown of a Superconducting Magnet

M.A. Lewis¹, R.P. Taylor^{1,2}, P.E. Bradley¹, I. Garaway¹, and R. Radebaugh¹

¹National Institute of Standards and Technology, Boulder, CO 80305

²University of Wisconsin-Madison, Madison, WI 53707

ABSTRACT

A single-stage pulse tube cryocooler was designed to provide rapid cooldown of a high-temperature superconducting (HTS) magnet that is part of a gyrotron required for the generation of high-power mm-wave (95 GHz) beams. These beams are used in the nonlethal weapons systems known as the Active Denial System. The optimized cryocooler is designed to provide 50 W of net refrigeration power at 50 K and is driven by a pressure oscillator that can produce up to 2.8 kW of acoustic power at 60 Hz. The rapid cooling technique makes use of a resonance phenomenon in the inertance tube and reservoir system to decrease the flow impedance and thereby increase the acoustic power through the system when the cold end is near room temperature. We use three different reservoir volumes at the end of the inertance tube with ball valves to select the optimum reservoir for any particular cold-end temperature. With the optimum reservoir connected, the cooler impedance at any temperature is better matched to that of the pressure oscillator, which allows for a greater input power and faster cooldown without hitting the end stops in the pressure oscillator. This paper discusses the construction and performance of the cryocooler. Initial measurements showed the presence of serious flow nonuniformities inside the pulse tube that led to poor performance. The steps taken to eliminate the nonuniformities and their effect on the cooler performance, are discussed. The cooling rates for different reservoir volumes with a 20 kg copper mass attached, which simulates a HTS magnet, are compared and discussed.

INTRODUCTION

The purpose of the pulse tube cryocooler is to provide cooling for a high-temperature superconducting (HTS) magnet made with second generation wire (YBCO) that is part of a gyrotron required for the generation of high-power (5 MW) mm-wave (95 GHz) beams. Such beams are used in the nonlethal weapons system known as the Active Denial System (ADS). The optimized cryocooler is designed to provide at least 50 W of net refrigeration power at 50 K and is to be driven with an existing pressure oscillator operating at NIST. The pressure oscillator can produce up to 2.8 kW acoustic power at 60 Hz. The fast cooldown technique makes use of a resonant phenomenon in the inertance tube and reservoir system to decrease the flow impedance and thereby increase the acoustic power flow through the system by about a factor of four above the optimized steady-state value used when the cold tip is at 50 K. This resonance phenomenon is produced by

reducing the volume of the reservoir, accomplished by valving off a portion of the reservoir. The reduced flow impedance obtained with the resonance phenomenon also provides a better impedance match to the pressure oscillator when the cold end is warm, which results in high compressor efficiency even during initial cooldown.

For a fixed acoustic power at the cold end, the acoustic power required from the pressure oscillator decreases at higher cold-end temperatures. The maximum acoustic power at the cold end of Stirling cryocoolers is fixed by the stroke of the displacer, but pulse tube cryocoolers can accept higher acoustic powers whenever the impedance of the inertance tube is reduced. The period required to cool a 20 kg mass (simulating the YBCO magnet) of stainless steel is predicted to be 1.0 hr for the pulse tube cryocooler designed here when the fast cooldown mode is used.

APPLICATIONS

Cryocoolers for use in military operations often need to cool quickly to the operating temperature to enable rapid deployment. The system of particular interest here is the cooling of a 3 T high-temperature superconducting magnet for use in a gyrotron to generate high-power millimeter waves at a frequency of 95 GHz. Such waves can be used as a nonlethal method for repelling personnel in crowd control. This system is known as the active denial system (ADS).¹ Figure 1 shows an artist's drawing of the system deployed on a military vehicle. To be operational the magnet must be cooled to the design temperature, which for a magnet made with YBCO (second-generation high-temperature superconducting wire) is a temperature of about 50 to 60 K. The mass of a YBCO magnet for this application is about 20 kg. Typically the cooldown period for this mass may be about 16 hours when a cryocooler designed for high efficiency and low mass is used. For the active denial system considered here, cooldown periods less than four hours are often desired. For mobile applications the system mass and power requirements should be minimized. The net refrigeration power required to maintain the magnet at 50 K is estimated to be 50 W. The cooldown period is inversely proportional to the refrigeration power provided by the cryocooler over the entire temperature range from ambient down to the operating temperature. Typically, the net refrigeration power available at room temperature is much larger than that available at the cold operating temperature, partly because the thermal losses, such as conduction, radiation, and regenerator ineffectiveness, are very small at room temperature.

To decrease the cooldown period the net refrigeration power should be increased beyond that normally available over the whole temperature range. However, the size and mass of the system will depend on the maximum net refrigeration power the system can provide at the cold-end operating temperature. The PV power provided by the compressor is highest when the cold end is at its lowest temperature, even though the net refrigeration power is higher at the higher temperatures. Ideally we need to find some method for increasing the net refrigeration power at the higher temperatures without increasing the size and mass of the system, and still keep the input power less than the maximum capability of the compressor. For Gifford-McMahon and rotary Stirling cryo-



Figure 1. Artist's concept of mobile Active Denial System (ADS) to beam high power mm-waves (95 GHz).

coolers, an increased speed at the higher operating temperatures can be used to provide a faster cooldown time. For Stirling and pulse tube cryocoolers using linear-resonant pressure oscillators (compressors), the speed cannot be increased significantly because the off-resonant condition of the compressor would lead to low efficiency. We describe here a method that should allow the cold head of a pulse tube cryocooler driven by a linear-resonant compressor to accept nearly the full PV power output of a compressor over the entire temperature range of the cold end. As a result, the cooldown period may be decreased by a factor of two or three compared with that of a Stirling cryocooler or a pulse tube cryocooler not utilizing the fast cooldown technique.²

MODELING AND OPTIMIZATION TECHNIQUES

The main analysis tools used here are REGEN3.2, PHASOR, ISOHX, and INERTANCE. The analysis tool PHASOR is a MathCad program that uses the conservation of mass and energy to tie all components together and visually indicate the relative phase of different oscillating parameters such as flow, pressure, and compressor volume variation when all these parameters are assumed to vary sinusoidally with time. REGEN3.2, developed at NIST, is used to design the regenerators of any regenerative-cycle refrigerator. ISOHX is used to analyze the heat transfer and pressure drop in the three isothermal heat exchangers (aftercooler, cold heat exchanger, and pulse tube warm heat exchanger), and INERTANCE is used to determine the inertance tube geometry to provide the proper flow impedance.

COMPONENTS OF THE APPARATUS

The pulse tube cryocooler apparatus consists of a compressor or pressure oscillator, instrument flange, regenerator, cold-end heat exchanger, pulse tube, warm-end heat exchanger, inertance tube flange, dual tube inertance tube, reservoir volumes, and associated valves.

Compressor

The pressure oscillator was developed specifically for NIST as a general-purpose laboratory pressure oscillator. Our experimental model provides 2.8 kW of acoustic power at 60 Hz, but it can also be made to resonate at 30 Hz by removing masses from the moving piston shaft. It uses flexure bearings to support the piston in the cylinder with no rubbing contact, and the use of a moving magnet configuration eliminates moving electrical leads. The 60 Hz impedance map for the pressure oscillator (compressor) was used in the optimized design of the pulse tube cryocooler to yield high compressor efficiencies. To best match the impedance of the compressor we designed the pulse tube cryocooler to meet the conditions in Table 1.

Regenerator

In the REGEN3.2 software, input parameters such as the mass flowrate at the regenerator cold end and its phase in relation to its pressure, along with average pressure and the pressure ratio at the cold end, can be varied to find the maximum COP for the regenerator. Other parameters determining maximum COP are the length, cross sectional area, and hydraulic diameter. Using various input parameters for optimization the regenerator outside diameter was 57.15 mm with a length of 48 mm and a wall thickness of 0.89 mm as shown in Table 2. The regenerator screen mesh was # 400 mesh stainless steel screens that were diffusion bonded and wire electrical discharge machined (EDM)

Table 1. Compressor design

Pressure ratio at warm end	1.3 to 1.5
Frequency	60 Hz
Maximum acoustic power	2.8 kW
Phase between mass flow and pressure at compressor	45° to 60°
Cold temperature	50 K
Warm temperature	300 K
Minimum net refrigeration power	50 W

Table 2. Regenerator and Pulse Tube Dimensions

$$P_0 = 2.5 \text{ MPa}, P_r = 1.30$$

	Regenerator	Pulse Tube
Outside diameter	57.15 mm (2.25")	34.93 mm (1.375")
Wall thickness	0.89 mm (0.035")	0.71 mm (0.028")
Inside diameter	55.37 mm (2.18")	33.50 mm (1.319")
Length	48 mm (1.89")	55.0 mm (2.17")
Mesh size	#400 μm (25.4 μm wire)	-
Porosity	0.686	-

for a slide fit into the regenerator tube. The stainless steel stack height was 7.67 mm, with 6 individual stacks placed into the regenerator. Each stack was separated by a single #80 mesh copper screen to enhance the regenerator performance by increasing the transfer heat conductance of the regenerator matrix.³

Pulse Tube

The function of the pulse tube is to provide an adiabatic element that can transport acoustic power through it in the presence of a temperature gradient. For a perfect pulse tube the acoustic power is constant from the cold end to the hot end of the pulse tube and no entropy is generated along the length. To approximate such a perfect pulse tube, two main conditions must be met: (1) the compression and expansion process within the pulse tube must be adiabatic, and (2) the volume displacement for a parcel of gas within the pulse tube should be small compared with the pulse tube volume. The first condition is met when the thermal penetration depth in the helium working fluid at the operating frequency is small compared with the tube radius. For a frequency of 60 Hz and a pressure of 2.5 MPa the thermal penetration depth in helium at 300 K is about 0.2 mm. At lower temperatures the thermal penetration depth is smaller. Adiabatic conditions would be approximated for a pulse tube diameter greater than about 4 mm. The second requirement is met by making the pulse tube volume at least 3 to 5 times the swept volume of the gas at the cold end. The optimized REGEN3.2 software calculated the cold end swept volume as 7.90 cm³. For a volume ratio of 3.0 the pulse tube volume should be at least 23.7 cm³ to provide proper thermal isolation between the two ends. A larger volume will improve the thermal isolation, but it leads to a larger phase shift required by the inertance tube. Because of the rather low temperature of 50 K and increased flow rate and swept volume at the cold end in the fast cooldown mode the volume ratio was increased to about 6. These conditions determined the pulse tube to have an outside diameter of 34.93 mm and a length of 55.0 mm with a wall thickness of 0.71 mm. Details are list in Table 2.

Heat Exchangers

Three isothermal heat exchangers were designed for the single-stage pulse tube refrigerator. They are the aftercooler, cold end heat exchanger and the warm end heat exchanger. These were designed by NIST software known as ISOHX. Specific details of the construction are listed in Table 3. Stacked copper screens were used as a matrix for these heat exchangers because they have high radial thermal conductivity, reduced axial thermal conductivity and high surface area for heat transfer. These heat exchangers used #100 mesh copper screen material with the screens stacked to a specific height and diffusion bonded, then wire EDM to a shrink fit into the appropriate copper flange. The flange and screen material were then diffusion bonded as a complete part for ideal thermal contact. Figure 2 and 3 show photos of the warm end and cold end heat exchangers, respectively. The pressure drops in these heat exchangers are relatively small. The gas volume for the aftercooler should be small compared with the gas volume in the regenerator, and the gas volume in the pulse tube heat exchangers should be small compared with that of the pulse tube.

Inertance Tube and Reservoir Volume

The complex impedance of the inertance tube was calculated with NIST software known as INERTANCE. The calculations were performed assuming perfectly adiabatic behavior in the

Table 3. Details for the Three Heat Exchangers

	Aftercooler	Cold HX	Warm HX
Diameter (mm)	50.8	34.9	34.9
Length (mm)	6.35	11.7	11.7
Mesh (copper)	#100	#100	#100
Porosity	0.647	0.600	0.600
Temperature (K)	300	50	300
Mass flow (g/s)	31.5	31.5	10.3

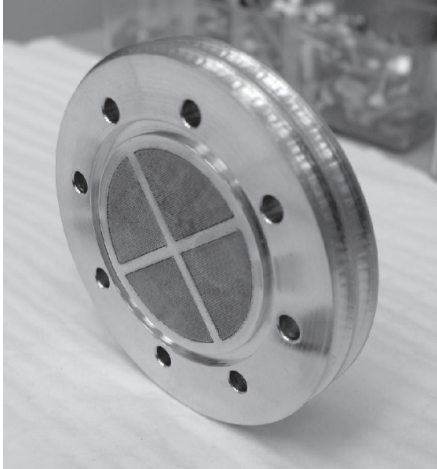

Figure 2. Warm end heat exchanger

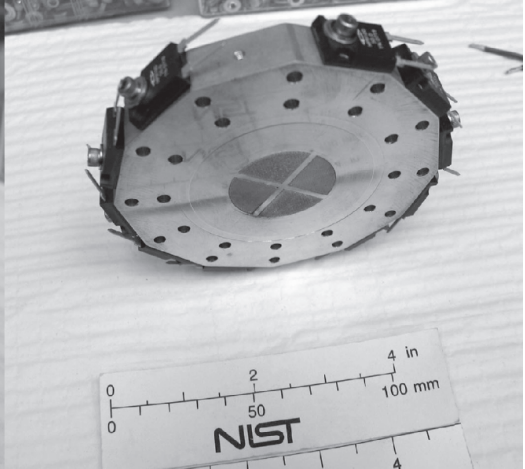

Figure 3. Cold end heat exchanger

inertance tubes. Such an assumption should be valid for such a large diameter tube where the radius is about 10 times the thermal penetration depth. The calculations were performed assuming perfectly adiabatic behavior in the inertance tubes. Such an assumption should be valid for a tube of such large diameter tube where the radius is about 10 times the thermal penetration depth. To achieve a phase of -25° at the cold end of the pulse tube, a phase of about -65° is required at the inertance tube entrance. Such a phase shift could be achieved by use of a double-diameter inertance tube with a 6.5 mm ID tube 1.35 m long and a 8.7 mm ID tube 1.92 m long connected to a 500 cm³ reservoir. The details are listed in Table 4. The impedance of this combination is such that it allows 200 W of acoustic power (PV power) flow for a pressure ratio of 1.3. Such a power flow at the cold end was calculated in the REGEN3.2 analysis. That same power flow will exist through the pulse tube and into the inertance tube, except for the small reduction through the warm end heat exchanger. The high gas velocity in the pulse tube can lead to large pressure losses at the ends if abrupt diameter changes are encountered. It is important that a gradual taper (6° half angle) be used at the end of the inertance tube and between the two diameters. Therefore, an inertance flange that has incorporated this tapered design connects the inlet to the inertance tube to the warm end heat exchanger. The connection between the two stainless steel tube includes a tapered section.

Table 4. Inertance Tube Dimensions
(Reservoir volume = 500 cm³)

	Small Tube (2/3 ΔP)	Large Tube (1/3 ΔP)
Mass flow at entrance (g/s)	11.1	14.3
Acoustic power input (W)	200.0	66.7
Inside diameter (mm)	6.50	8.7
Length (m)	1.352	1.921

LAYOUT OF THE PULSE TUBE REFRIGERATOR

The layout of pulse tube cryocooler is shown in Figures 4 and 5. Care is taken in the layout to provide good flow straightening. Also, a 6° tapered transition section is shown between the inertance tube and the pulse tube to reduce the velocity without dissipating the dynamic pressure head. This transition section was modified for the experiments to a conical design. A similar transition piece is placed at the reservoir end of the inertance tube. Without such transition elements the phase shift of the inertance tube could be reduced by several degrees. The length of the aftercooler is much shorter than the other two heat exchangers because the use of several water tubes in the aftercooler improves the radial heat transfer. Figure 6 and 7 show the individual installation of the cold end and warm end heat exchangers.

FAST COOLDOWN PROCEDURE

We have shown previously that the impedance of the inertance tube can be varied significantly by the size of the reservoir volume.⁴ As a result, the acoustic power at the inlet to the inertance tube for a fixed pressure amplitude can be varied considerably by varying the reservoir volume without changing the inertance tube. Such a condition represents a resonant effect in the system analogous to an LC resonance in an electrical system.^{5,6} Here *L* is analogous to the inductance of the inertance

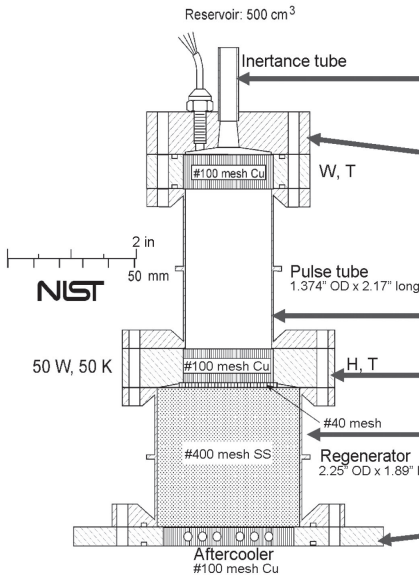

Figure 4. Schematic of cryocooler



Figure 5. Photo of cryocooler

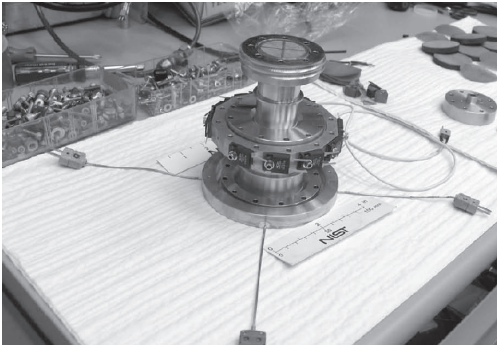

Figure 6. Warm end heat exchanger assembly.

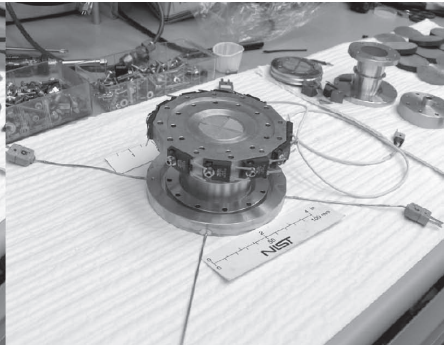

Figure 7. Cold end heat exchanger assembly.

tube and C is analogous to the compliance of the inertance tube and reservoir volume. For the system designed here a double-diameter inertance tube is used with a 500 cm^3 reservoir volume for steady-state operation at 50 K. The acoustic power flow at the entrance to this inertance tube is 200 W, and the phase of the impedance is 65° . When the reservoir volume is 80 cm^3 , the acoustic power flow becomes about 800 W, with a phase of 32° when the pressure ratio is fixed at 1.3. At a pressure ratio of 1.4, the acoustic power flow into the inertance tube becomes 1260 W and the phase angle decreases to 28° . The larger pulse tube discussed earlier is required to accommodate this large acoustic power flow because of the large swept volume at the cold end. The smaller phase is much less than the optimum phase for the case when the system is cold. However, when the system is warm such a phase is close to an optimum for the regenerator and for an impedance match with the compressor. This results in faster cooldown times. During start-up, when the system is at 300 K, the valve between the reservoirs is closed, so that the reservoir volume seen by the inertance tube is about 80 cm^3 . The high acoustic power flow into the inertance tube causes the acoustic power at the cold end to increase with a subsequent increase in the net refrigeration power when the system is warm. The regenerator and the pulse tube are not designed to accommodate the high power flow during normal operation at the low temperatures, but at high temperatures where the losses are small, the net refrigeration power is increased significantly by the higher acoustic power flow. When the cold end reaches some low temperature, the valve to the larger reservoir volume is opened so that the total reservoir volume seen by the inertance tube becomes 500 cm^3 . With that volume the system has the optimum impedance for operation at 50 K. The valves should be a ball or plug valve that offer a low flow resistance when opened. If desired, the valve could be electrically controlled to allow for automatic operation at the optimum temperature of the cold end.

EXPERIMENTAL RESULTS

The experimental data on the pulse tube cryocooler were at 2.5 MPa with 3.0 kW of electrical input power. The electrical input power to the compressor was increased rapidly for rapid cooldown time. When the full 500 cm^3 volume is used the electrical input power to the compressor is stroke limited until the temperature at the cold end is sufficiently low enough, about 200 K. This condition exists when the small two reservoir volumes are also used but the condition disappears at a much warmer cold end temperature, about 250 K. When using the one small reservoir volume it will no longer be stroke limited but will become current limited by the electrical power that the compressor is designed to operate at 25 A.

These initial experiments produced a low end temperature of about 102 K. These low end temperatures were much higher than expected from the apparatus and the cause for these differences can be attributed to a number of conditions. The gas flow temperature from the compressor through the aftercooler is much higher than those for which the operating conditions are designed for. These gas temperatures reach as high as 350 K, where the design temperatures at this location are about 300 K. This indicates that the aftercooler is not rejecting enough heat and undersized for these high mass flow rates. Temperature measured at the midpoint plane around the circumference of the regenerator and the pulse tube were also very high. Along with the high temperatures there was severe nonuniformity in the temperature profile through both the regenerator and the pulse tube. The initial tests show as much as 50 K differences in the centerline temperatures in the regenerator and 30 K differences in the pulse tube. These effects could be generated from gas flow jetting from the inertance tube through the warm end heat exchanger into the pulse tube. A number of experiments were run with small changes made to the flow coming into the warm end heat exchanger from the inertance tube. These included adding various screen materials into the inertance tube flange section. The original design was modified from a typical taper design to a conical design. At the location directly next the warm end heat exchanger, stainless steel screen discs inserted to improve the flow distribution into the warm end heat exchanger and pulse tube. These changes had very small effects on the low end temperature, and the system would not achieve temperatures below 100 K.

The diffusion bonded copper screens within the warm end heat exchanger began to deteriorate with the oscillating flow conditions and actually began to lose individual screens from the screen

stack in some of the pie segments of the warm end heat exchanger. Experiments were made to improve the performance of the warm end heat exchanger by introducing flow straightening screen discs within the pulse tube. These discs were made of a stack of diffusion bonded stainless steel screen that consisted of two #400 mesh screens sandwiched between some coarser screens that provided rigidity. This screen stack, along with three #80 mesh copper screen discs was installed directly up against the warm end heat exchanger at the warm end of the pulse tube. The copper screens were against the warm end heat exchanger with the stainless steel stack toward the cold end heat exchanger. By use of this configuration a low end temperature of 67 K was achieved. Using the maximum electrical input power to the compressor, and the full 500 cm³ reservoir volume this temperature was achieved in about 20 minutes. The nonuniformity in the temperature profile remained although the temperature differences within both the regenerator and the pulse tube were lowered. These differences remained about 30 K in the regenerator and about 20 K in the pulse tube. The copper screens were removed and using only the stainless steel screen stack at the warm end of the pulse tube next to the warm end heat exchanger resulted in a low end temperature of 70.4 K. The copper screens were reinstalled and additional tests were done under these conditions. The low end temperature obtained was higher than previous test results.

To improve the design, a #100 mesh diffusion bonded copper screen material was needed for the warm-end heat exchanger and a diffusion bonding screen material for the warm end and cold end heat exchangers needed to be replaced. This second diffusion bond material was heated in a vacuum furnace to a temperature of 1000 °C for 3 hours with some additional weight added to the screen stack. The compression of the screen stack is limited with the use of ceramic spacers modified to the final desired height of the screen stack. The original diffusion bonded temperature was 850 °C for less than 2 hours.

A second warm end heat exchanger was used that consisted of a single disc. Experiments were done with this new design and the newly diffusion bonded #100 mesh copper screen material. These experiments achieved a low end temperature of 67 K and improvements were seen in the temperature nonuniformity in both the regenerator and the pulse tube. The differential temperatures in both the regenerator and pulse tube were about 15K to 20 K. These low end temperatures were achieved in about 20 minutes by operating the experiment as previously described. Under the same conditions, an experiment was done using a single 500 cm³ reservoir instead of the three individual reservoirs. These tests achieved a low end temperature of 76.5 K.

The diffusion bonded copper screen stack was determined to be more effective than the original stack and therefore the screens in both the pie segmented sections of the warm end and cold end heat exchangers were remade with the new screen material. The copper flanges along with the new diffusion bonded screen material were diffusion bonded a second time as a complete assembly. During the same period when these improvements were being carried out, design drawings were in place for an improved aftercooler for the apparatus. The aftercooler construction was not completed and it was decided to continue on with experiments using the newly diffusion bonded cold end and warm end heat exchanger components.

Several experiments were completed with these improved components. The first test consisted of the original setup not using any screen material in the pulse tube. As done previously the system was operated at its stroke limit until reaching a cold end temperature of about 200 K was reached, then at full electrical power, 3 kW. A low end temperature of 76 K was achieved in about 20 minutes. An experiment using the stainless steel diffusion bonded stack along with the three copper screen at the warm end of the pulse was redone because of the positive results that were obtained previously. The low end temperature achieved was 80 K in the same period of 20 minutes. The screens stacks were removed because the performance was not improved and the experimental tests run again as in the original configuration. The low end temperature achieved this time was only 88.9 K. The period needed to reach this temperature increased to about 30 minutes. The significant change that was seen was that in the first two experiments where temperatures of 76 and 80 K were achieved the difference in temperature distribution across the regenerator and pulse tube were about 40 K and 15 K, respectively, where as at 88.9 K the temperature differential rose to about 50 K and 40 K, respectively. Additional investigation and analysis needs to be done to explain why this temperature change occurred. This low end temperature of about 88 K reoccurred in additional experiments.

A series of heat load temperature experiments was conducted with the full reservoir volume and the various combinations of reservoir volumes available, as shown in Figure 8. For each reservoir volume the low end temperature was established and increasing electrical power supplied to the cold-end heaters to determine net refrigeration power. Individual data points were taken once the low end temperature reached stability. The electrical input power to the compressor was maintained at the maximum power of 3 kW for all data points except at full reservoir volume capacity at the warmer temperature where the compressor would be stroke limited. At these data points the electrical input power needed to be lowered to avoid the stroke limitation. An additional set of data were taken at a constant pressure ration of 1.3 at the warm end or inertance inlet.

The data shows the net refrigeration power verses temperature for the full reservoir of 500 cm³, two small reservoirs volumes combined to equal to 180 cm³, and the single reservoir volume of 90 cm³. The net refrigeration using the two small reservoirs is 30-40 W higher from 270 K until about 150 K. This difference in refrigeration power decreases until a crossover region exists at about 130 K where the net refrigeration power increases by use of the full 500 cm³ reservoir volume. The use of the single small reservoir shows no benefit. The worst case condition is the 1.3 pressure ratio.

CONCLUSIONS

The use of multiple reservoir volumes with associated valves allows the cryocooler to obtain higher net refrigeration which lead to faster cooldown. A crossover in the load curve data for the reservoir volumes of 500 cm³ and 180 cm³ shows an operating temperature that would yield higher net refrigeration power, which would optimize the operation of the cryocooler.

Design improvements are being made to the aftercooler for improved heat rejection and temperature control to the inlet of the regenerator. Gas temperatures reaching 350 K at the inlet to the regenerator, the achievable low end temperature at the cold end is severely limited. The nonuniformity in the temperatures in both the regenerator and the pulse tube indicates jetting in the flow stream and has a direct effect on the low end temperature. System changes to influence a more uniform flow profile are being investigated.

A new pulse tube design may have positive effects for the temperature nonuniformity and contribute to an improved performance. Changes to the aspect ratio are currently being developed with a different pulse tube being machined and to be used in future experiments.

Although the pulse tube cryocooler did not reach its desired low end temperature, many positive results were obtained. There are clearly further specific changes in design that could enhance the overall performance and the design parameters may be obtainable.

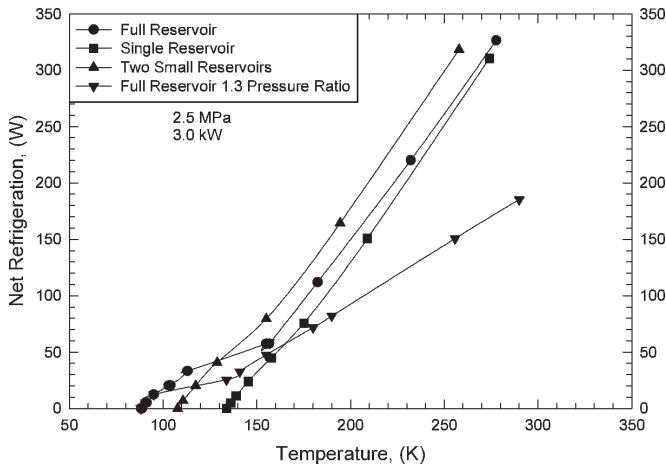

Figure 8. Net refrigeration vs. temperature

ACKNOWLEDGMENT

Funding from Cryomagnetics and the U.S. Air Force is acknowledged.

REFERENCES

1. Beason, D., *The E-Bomb*, Da Capo Press, Cambridge, MA (2005) .
2. Radebaugh, R., O’Gallagher, A., Lewis, M.A., and Bradley, P.E., Proposed Rapid Cooldown Technique for Pulse Tube Cryocoolers,” *Cryocoolers 14*, ICC Press, Boulder, CO (2007), pp. 231-240.
3. Dietrich, M., Yang, L.W., Thummes, G., “High-power Stirling-type pulse tube cryocooler: Observation and reduction of regenerator temperature-inhomogeneities,” *Cryogenics*, Vol. 47 (2007), pp. 206-314.
4. Lewis, M.A., Bradley, P.E., Radebaugh, R., “Impedance of Inertance Tubes,” *Adv. in Cryogenic Engineering*, Vol. 51, Amer. Institute of Physics, Melville, NY (2006), pp.1557-1563.
5. Radebaugh, R., Lewis, M., Luo, E., Pfothner, J.M., Nellis, G.F., and Schunk, L.A., “Inertance Tube Optimization for the Pulse Tube Refrigerators,” *Adv. in Cryogenic Engineering*, Vol. 51, Amer. Institute of Physics, Melville, NY (2006), pp.59-67.
6. Luo, E., Radebaugh, R. and Lewis, M., “Inertance Tube Models and their Experimental Verification,” *Adv. in Cryogenic Engineering*, Vol. 49B, Amer. Institute of Physics, Melville, NY (2004), pp.1485-1489.